

OPERATION, PARTS AND SAFETY MANUAL

SIGNODE®

AMT-58

COMBINATION STRAPPING TOOL

**IMPORTANT!
DO NOT DESTROY**

**It is the customer's responsibility to
have all operators and servicemen
read and understand this manual.**

Contact your local Signode representative
for additional copies of this manual.

READ ALL INSTRUCTIONS BEFORE OPERATING THIS SIGNODE PRODUCT

WARNING

READ THESE INSTRUCTIONS CAREFULLY.

FAILURE TO FOLLOW THESE INSTRUCTIONS CAN RESULT IN SEVERE PERSONAL INJURY.

GENERAL SAFETY CONSIDERATIONS

1. STRAP BREAKAGE HAZARD.

Improper operation of the tool or sharp corners on the load can result in strap breakage during tensioning, which could result in the following:

- A sudden loss of balance causing you to fall.
- Both tool and strap flying violently towards your face.

Failure to place the strap properly around the load or an unstable or shifted load could result in a sudden loss of strap tension during tensioning. This could result in a sudden loss of balance causing you to fall.

Read the tool's operating instructions. If the load corners are sharp use edge protectors. Place the strap correctly around a properly positioned load.

- Positioning yourself in-line with the strap, during tensioning and sealing, can result in severe personal injury from flying strap or tool. When tensioning or sealing, position yourself to one side of the strap and keep all bystanders away.

2. TRAINING.

This tool must not be used by persons not properly trained in its use. Be certain that you receive proper training from your employer. If you have any questions contact your Signode Representative.

3. EYE INJURY HAZARD.

Failure to wear safety glasses with side shields can result in severe eye injury or blindness. Always wear safety glasses with side shields which conform to ANSI Standard Z87.1 or EN 166.



4. FALL HAZARD.

Maintaining improper footing and/or balance when operating the tool can cause you to fall. Do not use the tool when you are in an awkward position.

5. CUT HAZARD.

Handling strap or sharp parts could result in cut hands or fingers. Wear protective gloves.



6. TOOL CARE.

Take good care of the tool. Inspect and clean it daily, lubricate it weekly and adjust when necessary. Replace any worn or broken parts.

7. WORK AREA.

Keep work areas uncluttered and well lighted.

⚠ WARNING

Use the correct Signode products for your application. If you need help contact your Signode Representative.

Signode tools and machines are designed and warranted to work together with Signode strapping and seals. Use of non-Signode strap, seals and/or manufactured or specified replacement parts may result in strap breakage or joint separation while applying strapping to a load or during normal shipping and handling. This could result in severe personal injury.

SAFETY PROCEDURES FOR TOOL OPERATION

1. OPERATION SEQUENCE.

Before using this tool, read its Operation and Safety Instructions contained in this manual.

2. This tool is a crimp type sealer. A properly formed joint will appear as shown in the illustration. If the joint does not appear as shown, then the operator must proceed as follows:

- A. Ensure that the tool's operating instructions are being followed before applying another strap.
- B. Cut the strap off and apply another.

If the joint still does not appear as shown, then inspect the tool for worn and/or damaged parts. Replace tool parts as needed. **NEVER HANDLE OR SHIP ANY LOAD WITH IMPROPERLY CRIMPED JOINTS.** Miscrimped joints may not secure the load and could cause serious injury.

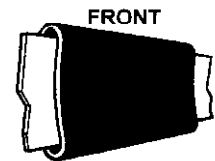
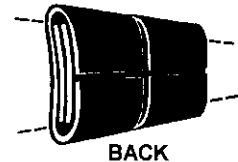

3. Tuck strap end back into the dispenser when not in use.

CUTTING TENSIONED STRAP

FLYING STRAP HAZARD.

Using claw hammers, crowbars, chisels, axes or similar tools will cause tensioned strap to fly apart with hazardous force. Use only cutters designed for cutting strap. Read the instructions in the cutters manual for proper procedure in cutting strap. Before using any Signode product read its Operation and Safety Manual.

TABLE OF CONTENTS	Page
General Safety Instructions	2
Specifications	4
Operating Instructions	5
Sealing Operation	6
Parts Replacement	9
Maintenance	10
Parts List	11
Options	18

 WARNING

Signode tools and machines are designed and warranted to work together with Signode strapping and seals. Use of non-Signode strap and seals and/or manufactured or specified replacement parts may result in strap breakage or joint separation while applying strapping to a load or during normal shipping and handling. This could result in severe personal injury.

AMT-58
Part No. 306930

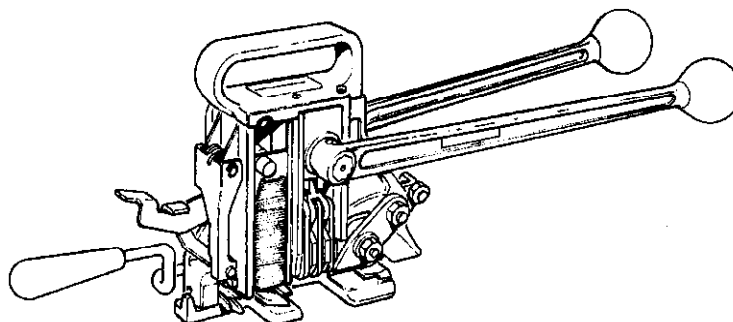

TOOL SPECIFICATIONS

MODEL	STRAP			SEALS
	TYPE	WIDTH	THICKNESS	
AMT-58	High Strength Tenax	5/8" (16mm)	0.030" to 0.040" (0.8 - 1.0mm)	58-AMT

OPERATING INSTRUCTIONS

⚠ WARNING

Wear safety glasses.

Stand to one side of the strap while tensioning.

Make sure all bystanders are clear before proceeding.

LOADING SEALS

An extension on the seal pad (61) closes the top strap loading slot as a reminder to add seals. Raise the seal pad assembly and insert a stack of seals in the side of the seal magazine. Make sure the seal stack is pushed all the way in.

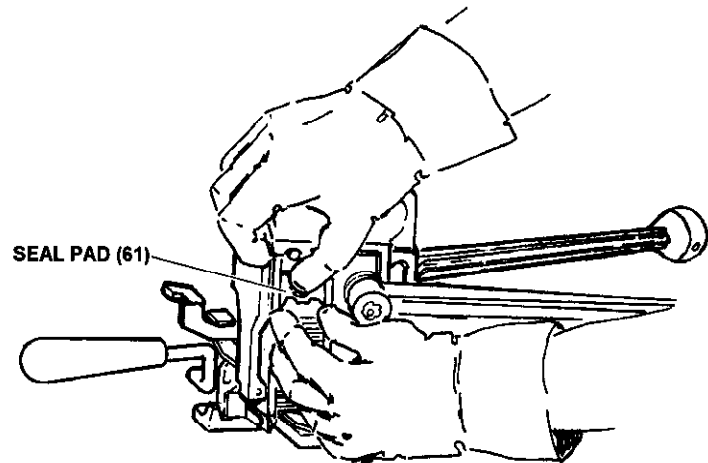

STRAPPING TIE

1. Encircle the package with the strap and insert the bottom strap-end under the rocking gripper. Push it forward until it contacts the gripper stem. Press the gripper trigger to actuate the holding gripper.

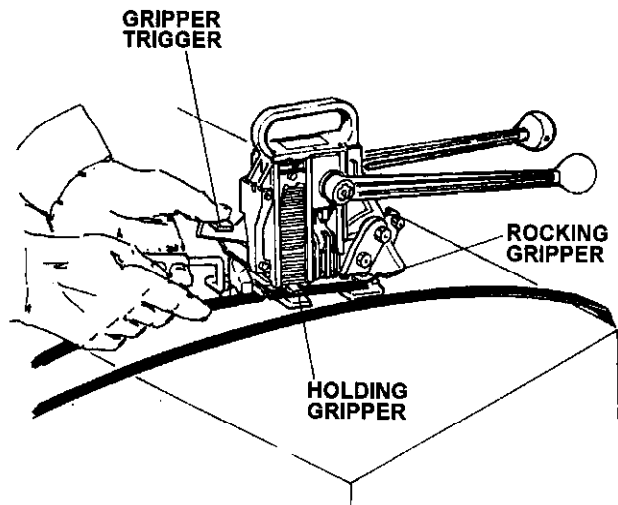
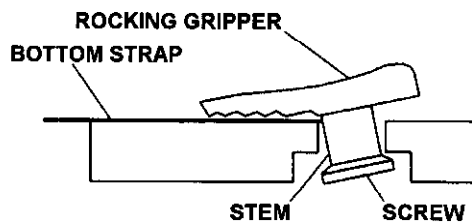

OPERATING INSTRUCTIONS Continued

2. Insert the top strap under the feedwheel and insert it sideways into the slot of the strap latch. Pull the excess slack from the strap.

NOTE:

Refer to page 18 if using the optional tension sensing handle. Continue with the following instructions if using the standard handle.

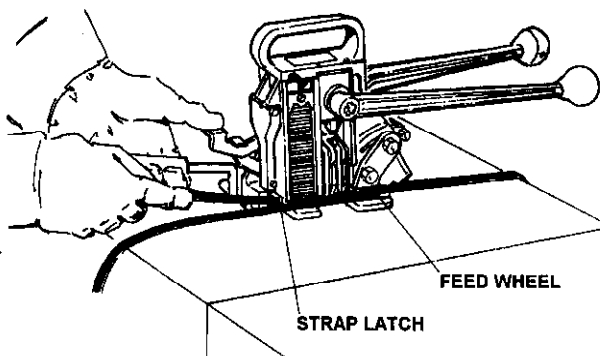

3. While standing to one side of the strapping line, pull the tensioning handle back then push it forward. Repeat this action until the desired tension has been drawn.

NOTE: Excessive tension will cause strap milling.

Do not push the handle too far forward, as a loss of tension could occur. Note the dotted line in the figure.

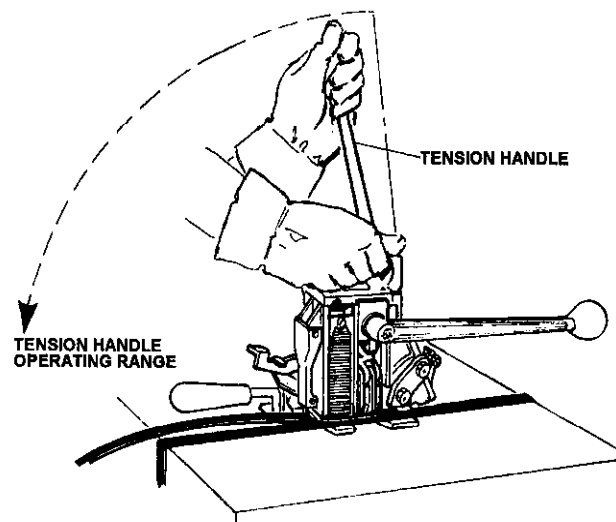

4. Complete the sealing and cut off action by pulling the sealing handle to its full rear position.

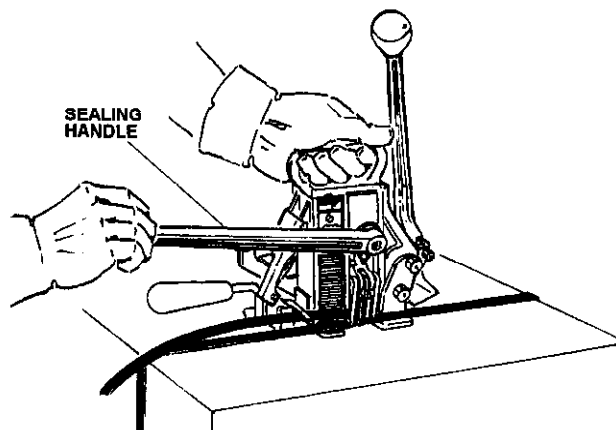

5. To remove the tool from the tensioned strap, return both the tensioning and sealing handles to their forward positions. Place your left hand on the tensioning handle and your right hand on the knob. Swing the rear of the tool to your left until it is free of the strap. Inspect the joint to make sure the tool has properly crimped the seal.

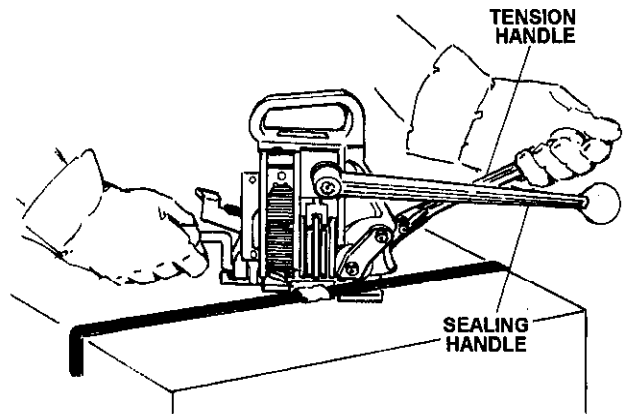

SEALING OPERATION

This tool is a crimp type sealer. A properly formed joint will appear as shown in the illustration. If the joint does not appear as shown, then the operator must proceed as follows:

- A. Ensure that the tool's operating instructions are being followed before applying another strap.
- B. Cut the strap off and apply another.

If the joint still does not appear as shown, then inspect the tool for worn and/or damaged parts. Replace tool parts as needed. **NEVER HANDLE OR SHIP ANY LOAD WITH IMPROPERLY CRIMPED JOINTS.** Miscrimped joints may not secure the load and could cause serious injury.

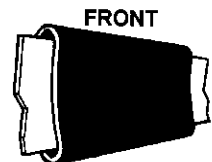
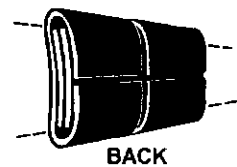

PARTS REPLACEMENT & ADJUSTMENTS

Refer to pages 13, 14, and 15, for detailed part descriptions and proceed as follows:

MAGAZINE AND SEALER MECHANISM

1. Remove the seals from the magazine (65) and the sealer jaws.
2. Release the gripper lever (60) by pressing down on the gripper trigger (56).
3. Loosen the cutter adjustment set screw (9).
4. Remove the two magazine screws (6 and 8) on the left side of the sealer frame.
5. Remove the two socket head cap screws (37) from the bottom of the tensioner frame (39).
6. Pivot the rear of the tensioner frame away from the sealer frame and tilt the top of the magazine away from the sealer mechanism and lift the magazine assembly out.
7. Remove the sealer mechanism from the sealer frame.

The magazine and the sealer mechanisms are now accessible for examination and replacement of worn or broken parts. The sealer mechanism is serviced by removing the cutter blade (75). Clean all parts. Replace jaws and crimpers (76, 77 and 78) as required. Note that the outer jaws can be reversed front to back to provide new cutting edges, thus doubling the life of the parts. After the necessary repairs have been made, grease the parts or apply light machine oil.

To reassemble:

1. Place the sealer handle in a horizontal position and insert the sealer mechanism. The hook on the sealer cam (89) must be placed over the cam roller (3) in the sealer frame.
2. With the sealer mechanism in place, push down lightly on the sealer handle to keep the sealer mechanism in place and insert the magazine assembly by placing the lower portion of the magazine between the sealer mechanism and the sealer frame. Tip the top forward to bring it into proper alignment.
3. Be sure the strap guide spring (36) is in its proper position in the tensioner frame. Swing the tensioner frame up against the sealer frame and insert and tighten the two socket head cap screws (37) through the tensioner frame.
4. Insert the magazine screws (6 and 8) through the sealer frame and into the magazine. Snug - do not tighten at this time.
5. Move the sealer handle to the vertical position to bring the sealer mechanism to the full down position. Adjust the cutter adjustment screw (9) and tighten both magazine screws (6 and 8).
6. Insert a stack of seals into the magazine. Operate the sealer mechanism through 3 or 4 cycles to check tightness of the cutter adjustment screw and see that the seals feed properly. If the sealer mechanism is excessively tight, back off the cutter adjustment set screw slightly. Next, apply a strap under tension to be sure that all elements of the tool operate properly.

EJECTOR AND EJECTOR LEVER ASSEMBLY

1. Remove the seals from the magazine (65).
2. Remove the Truarc (49) from the left side of the ejector pin (64).
3. Drive out the ejector pin from the tension handle side.
4. Remove the ejector lever spring (55).
5. Hold the gripper lever (60) down and pull out the ejector lever (50).

PARTS REPLACEMENT & ADJUSTMENTS Continued

To disassemble the ejector:

1. Remove the Truarc (53) from the ejector pin (54).
2. Remove the pin (54), ejector (52), and spring (51). Replace the ejector lever and/or the ejector as necessary.
3. Reassemble with the new ejector by following the above steps in reverse order.

NOTE: If only the ejector needs to be replaced, it can be removed without removing the ejector lever by following the above three steps.

To reassemble the ejector lever:

1. Insert the ejector (52) into the cutter block (67) slot. Hold the gripper lever (60) down and slide the ejector lever (50) into position.
2. Start the ejector pin (64) through the right side of the ejector lever and the magazine.
3. Insert the ejector lever spring (55).
4. Insert a punch from the tension handle side to hold the spring in alignment.
5. Tap the ejector pin (64) in from the sealer handle side, removing the aligning punch at the same time.
6. Push on the lower part of the ejector lever (50) to align the holes on the left side of the magazine. Finish tapping in the ejector arm pin (64).
7. Replace the Truarc (49).
8. Insert seals in the magazine.

Operate the sealer mechanism through 3 or 4 cycles to determine that the seals feed properly. Next, apply a strap under tension to be sure that all elements of the tool operate properly.

FEEDWHEEL (43)

To change a dirty or worn feedwheel, remove the left-hand threaded nut (47) from the feedwheel shaft (32) and the lock nut (45) from the support shaft (22). With the gear housing (31) in the up position, remove the right-hand washer (25), the side plate (44) and the feedwheel (43). Replace the feedwheel and reassemble the parts in reverse order.

ROCKING GRIPPER (48)

Turn the tool on its side. The gear housing should be in the up position. Remove the flat head socket cap screw (49) from the rocking gripper stem (48).

Push the rocking gripper up and out. Insert a new rocking gripper and reinstall the screw.

CUTTER (75)

If the cutter does not cut properly, loosen the shoulder bolt (6) and cap screw (8), and turn set screw (9) inward to remove the clearance between the cutter blade (75) and the cutter block (67). Adjust with jaws in the down position. Do not over-tighten as the sealing mechanism can be bound by this adjustment. When the adjustment has been made, retighten the shoulder bolt and cap screw.

MAINTENANCE

Clean tool and apply a light coat of Lubriplate 3000-W (P/N 010739) to all moving parts on a weekly basis.

TROUBLESHOOTING

The following items are the most common tool symptoms if problems occur. For symptoms or remedies not shown, contact your Signode service representative for additional information and details. The following tool symptoms are shown in this manual:

- #1 - Feedwheel (43) slips on top strap.
- #2 - Bottom strap slips out during tensioning.
- #3 - Tool breaks strap during removal or tensioning.
- #4 - Seal not fed properly.
- #5 - Joint failing after tool removed.
- #6 - Excessive effort to seal.
- #7 - Tool will not cut after sealing.

#1 SYMPTOM: Feedwheel (43) slips on top strap during tensioning.	
CAUSE	REMEDY
1. Feedwheel teeth packed with dirt or grit.	1. Clean feedwheel with brush.
2. Feedwheel teeth worn or chipped.	2. Replace feedwheel.
3. Bushing in side plate worn.	3. Check I.D. of bushing to determine if hole is elongated. Replace if visually elongated.
4. Strap not aligned properly - side plate coming down strap.	4. Align straps in tool properly.

#2 SYMPTOM: Bottom strap slips out of tool during tensioning.	
CAUSE	REMEDY
1. Rocking gripper (48) teeth packed with dirt or grit.	1. Clean gripper teeth with wire brush.
2. Rocking gripper teeth worn or chipped.	2. Replace gripper.

#3 SYMPTOM: Tool breaks strap at feedwheel, gripper, corner of load, or at joint during tool removal or tensioning.	
CAUSE	REMEDY
Excessive applied tension or strap in use is insufficiently lubricated.	Apply less tension or use lubricated strapping. Tension setting is set too high on optional tension wrench, readjust per instructions on page 18.

#4 SYMPTOM: Seal is not properly fed from magazine stack into sealer jaws.	
CAUSE	REMEDY
1. Seal stack damaged or excessively curved.	1. Turn stack around or use different stack of seals.
2. Seal not aligned with cutter blade and jaws.	2. Adjust set screw (2A) until seal feeds unobstructed .
3. Worn or broken ejector.	3. Replace worn or broken parts.

#5 SYMPTOM: Joint failing after tool is removed.	
CAUSE	REMEDY
1. Worn sealer mechanism parts.	1. Examine sealer mechanism for worn pins, jaws and crimpers.
2. Application related; i.e. strap not strong enough to contain load; load subjected to impact, load expands after strapping or load has very sharp corners.	2. Review application to determine that strap and tool in use is adequate for application.

#6 SYMPTOM: Excessive effort needed to seal.	
CAUSE	REMEDY
1. Strap not aligned properly.	1. Remove and realign strapping.
2. Dirty tool or lack of lubrication.	2. Clean sealer parts and replace worn or broken parts. Lubricate tool with machine oil or grease.
3. Seals are not being fully fed into sealer jaws.	3. Carefully move seal back into magazine and remove. Adjust set screw (2A) as necessary.

#7 SYMPTOM: Tool will not cut off strap after sealing.	
CAUSE	REMEDY
1. Cutter block (67) is out of adjustment.	1. Adjust cutter block, see page 10.
2. Cutter blade (75) is worn.	2. Replace cutter blade.
3. Cutting leg on cutter block (67) is worn or broken.	3. Replace cutter block.

OPTIONAL TENSION SENSING HANDLE

Kit No. 306936

The AMT-58 can be equipped with an optional tension sensing handle. During the application of tension the handle will "CLICK" when an appropriate "pre-set" tension level has been reached. This handle allows the operator to set the tool at tension levels that will not damage certain types of packages. It will also prevent milling of the strap by the feedwheel.

OPERATION, Continued from page 6:

3. While standing to one side of the strapping line, pull the tensioning handle back then push it forward. Repeat this action until the tension handle makes a "CLICK" noise at the pre-set tension setting.

The tension handle is factory set to "CLICK" when strap tension reaches 275 to 375 pounds of tension. STOP TENSIONING STRAP ONCE THE HANDLE HAS "CLICKED". The "CLICK" can be both heard and felt through the handle.

NOTE: Do not push the handle too far forward, as a loss of tension could occur. Note the dotted line in the figure.

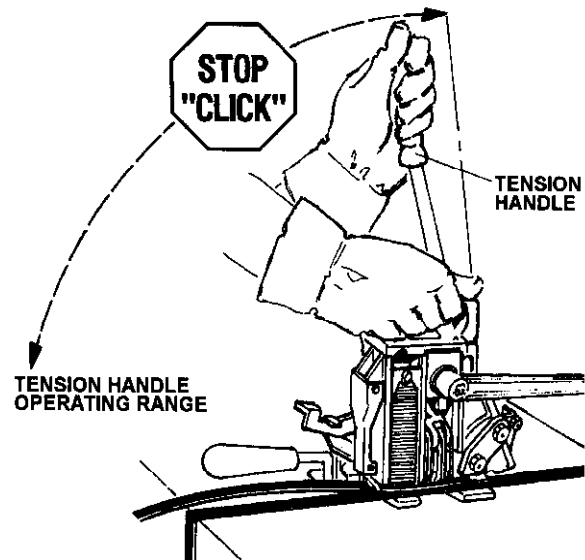

ADJUSTMENTS

The tension handle can be adjusted to indicate a lower or higher strap tension level. The handle is adjusted as follows:

1. Insert a flat blade screw driver into the slot of the lock plug. Loosen the lock plug by turning it counter-clockwise. If the handle has a safety pin, do not back out the lock plug any further than the locking pin.

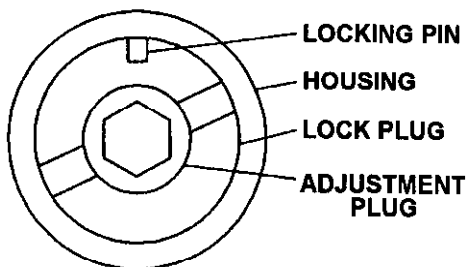

2. Insert a hex wrench through the lock plug and into the adjustment plug. Turning the adjustment plug clockwise increases the torque setting of the handle, turning the plug counter-clockwise decreases the torque setting.
3. Turn the adjustment plug in 1/4 turn increments only. Operate the tool between each adjustment until the handle clicks at the desired tension level.

WARNING

Strap breakage hazard. Strap can break while tension is being increased. Stand to one side of the strap as it is being tensioned.

4. Once the desired tension level has been established, re-tighten the lock plug.

SIGNODE NEW TOOL WARRANTY

Signode Engineered Products Warrants that a new Signode strapping tool will operate per functional specifications for a period of sixty (60) days after the date of shipment to the owner's place of business. Normal wearing parts, as outlined in the Operation, Parts & Safety manual, are covered by a thirty (30) day warranty unless, in Signode's judgement, these parts have been subjected to abnormal or extreme usage. Signode's sole liability hereunder will be to repair or replace, without charge, F.O.B. Signode's Glenview, Illinois plant, any tool which proves to not operate per functional specifications within the stated period. Signode reserves the right to replace any tool which proves not to operate per functional specifications with a new or like-new tool of the same model if in Signode's judgement such replacement is appropriate. Any new replacement tool provided to an owner will carry a full sixty (60) day warranty. Any warranty repaired tool or like-new replacement tool will carry a warranty for the balance of the time remaining on the initial sixty (60) day warranty. This warranty will be extended to compensate for the time the tool is in Signode's possession for warranty repairs.

This warranty is void as to any tool which has been: (I) subjected to mis-use, misapplication, accident, damage, or repaired with other than genuine Signode replacement parts, (II) improperly maintained, or adjusted, or damaged in transit or handling; (III) used with improperly filtered, unlubricated air or improper strapping material, (IV) in Signode's opinion, altered or repaired in a way that affects or detracts from the performance of the tool.

SIGNODE MAKES NO WARRANTY, EXPRESSED OR IMPLIED, RELATING TO MERCHANTABILITY, FITNESS OR OTHERWISE EXCEPT AS STATED ABOVE AND SIGNODE'S LIABILITY AS ASSUMED ABOVE IS IN LIEU OF ALL OTHERS ARISING OUT OF OR IN CONNECTION WITH THE USE AND PERFORMANCE OF THE TOOL. IT IS EXPRESSLY UNDERSTOOD THAT SIGNODE SHALL IN NO EVENT BE LIABLE FOR ANY INDIRECT OR CONSEQUENTIAL DAMAGES INCLUDING, BUT NOT LIMITED TO, DAMAGES WHICH MAY ARISE FROM LOSS OF ANTICIPATED PROFITS OR PRODUCTION, SPOILAGE OF MATERIALS, INCREASED COSTS OF OPERATION OR OTHERWISE.

Considerable effort has been made to ensure that this product conforms to our high quality standards. However, should you experience any difficulties, please contact your Sales Representative providing samples and the manufacturing code specified on the tool.